



SILEXA®



## RESTAURANT, CAFE & HOSPITALITY

---

EXPLORE HOW OUR PRODUCTS CAN SIMPLIFY YOUR DAILY OPERATIONS AND IMPROVE EFFICIENCY. FIND THE IDEAL SOLUTION TAILORED TO YOUR NEEDS.



## EFFICIENCY ENHANCEMENT IN THE HOSPITALITY DAILY ROUTINE

In restaurants and inns, we offer a variety of solutions to make daily operations more efficient and comfortable. A modern **cash register system** ① combined with the **SILEXA Tower Slim** ②, the **Tower Aperol Spritz** ③, and the **Tower Spumante** ④ ensures that essential beverages like sparkling and still water, beer, wine, and mixed drinks are always available. The integration of the espresso machine via the **SILEXA Coffee Box** ⑤, which can be directly connected, is particularly handy.

## COMPLEX TAPPING AND CONTROL SYSTEMS FOR LARGER OPERATIONS

For restaurants and businesses needing comprehensive cash register and control solutions, we recommend the **SILEXA Dispenser** ⑥ along with the **SILEXA Tower** ⑦ for beer. Additionally, the espresso machine and the **SILEXA Bottle Tap Fix** ⑧ can be incorporated to ensure maximum control and efficiency.

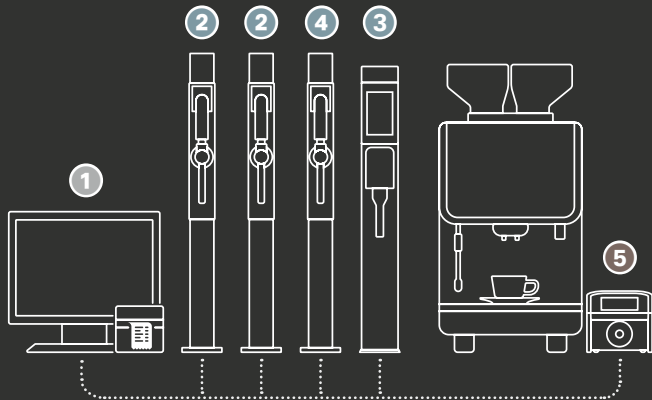

## SMOOTH ORDERING AND KITCHEN OPERATION

Food and drink orders are taken through the touchscreen **cash register system** ⑨ or a **mobile ordering solution** ⑩, while the drinks are directly released and displayed at the **SILEXA tap stations**. Simultaneously, meals are clearly transmitted to a **kitchen display** ⑪ in sequence, ensuring a seamless kitchen flow.

## OPTIMAL BEVERAGE QUALITY THROUGH INNOVATIVE TECHNOLOGY

Behind the scenes, our high-quality beverage technology ensures top quality. A cooling and carbonation system guarantees perfect sparkling water and cools the entire pipeline system. The automatic **SILEXA KEG Switcher** ⑫ and the integrated cleaning system **SILEXA Draft Line Cleaner** ⑬ provide additional convenience and save unnecessary foot traffic.

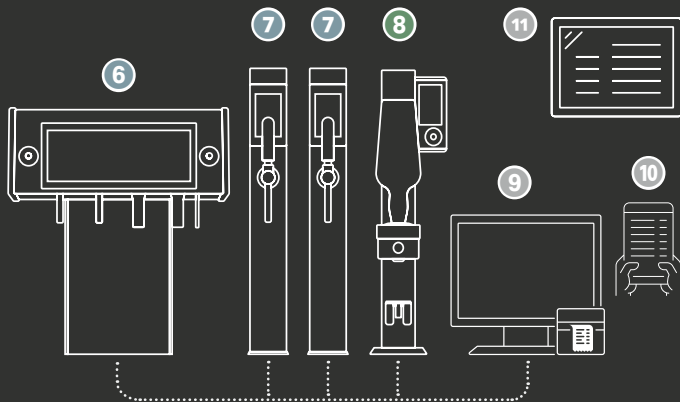



12

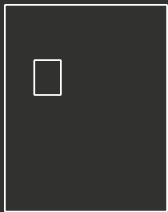

13

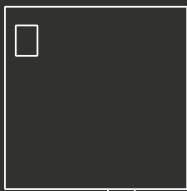

## TABLE RESERVATION SYSTEM

With modern **table reservation systems** <sup>14</sup>, reservations are managed efficiently and individually, whether for restaurants or event locations. The software integrates seamlessly into your operation, automating capacity planning and guest management. Reservations can be made around the clock via your website or often via Google as well. Automatic reminders via SMS or email reduce no-shows and enhance customer satisfaction.

## BACK OFFICE AND BI SOLUTION

With the **back office system and its BI functions** <sup>15</sup>, you maintain control over your finances and can optimally manage all operational processes in the background.



## DELIGHT GUESTS WITH CUSTOMER LOYALTY APPS

State-of-the-art **customer loyalty apps** <sup>16</sup>, often provided by the cash register supplier or third-party companies, take your loyalty program to the next level. For example, a simple point system rewards guests for their visits. Coupons and bonus promotions are digitally managed and can be used across branches. In conjunction with **PourMyBeer** <sup>17</sup>, guests can tap their own beer at the tap wall or directly at the table – saving staff and offering an unforgettable experience.

## FRESH BEER TO GO WITH THE SILEXA GROWLER FILLER

The **SILEXA Growler Filler** <sup>18</sup> is the perfect solution for brewpubs and breweries to fill fresh beer directly into bottles. Without carbonation loss, the beer is filled precisely and consistently in quality. Easy to operate and efficient, it allows your guests to take their favorite beer home while your brewery benefits from a clean, fast filling process.

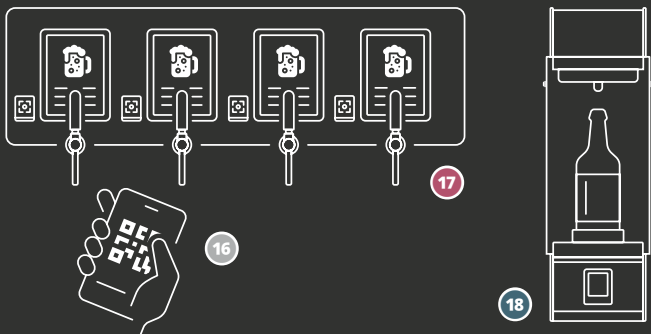

## SOLUTIONS FOR SELF-SERVICE RESTAURANTS

In self-service restaurants, the cash register system is combined with intuitive **self-service ordering terminals** <sup>19</sup>, allowing guests to place orders independently. Food orders are efficiently transmitted to the connected **kitchen displays** <sup>11</sup>, ensuring smooth kitchen operations. For beverages, a QR code ticket is printed, enabling guests to serve themselves at the **PourMyBev station** <sup>20</sup>, including options like Free Refill and flexible ticket validity.

## TAILOR-MADE SOLUTIONS FOR INDIVIDUAL NEEDS

Since we develop all the systems ourselves, we provide almost limitless options to address the specific needs of our customers and to optimize the self-service experience.

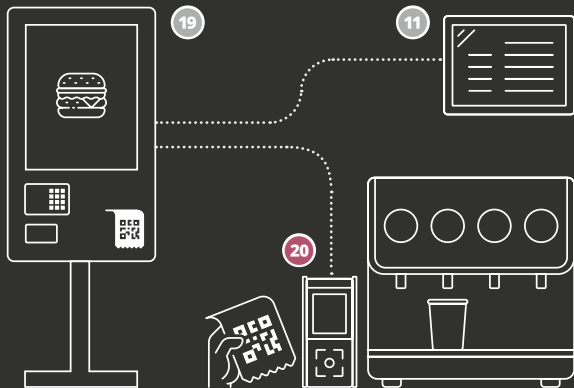

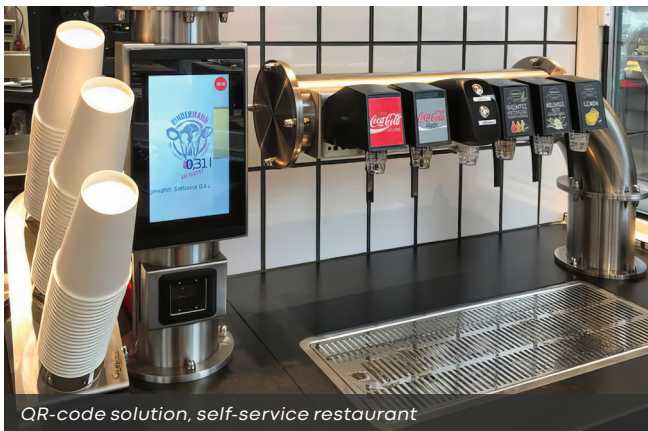



**SILEXA**®



## **DISCOTHEQUE & NIGHTCLUB**

---

EXPLORE HOW OUR PRODUCTS CAN SIMPLIFY  
YOUR DAILY OPERATIONS AND IMPROVE  
EFFICIENCY. FIND THE IDEAL SOLUTION  
TAILORED TO YOUR NEEDS.



## EFFICIENT PREPARATION OF MIXED DRINKS

In nightclubs, the **SILEXA Dispenser ①** plays a central role as it automates the preparation of a variety of mixed drinks. Popular drinks such as Gin Tonic, Vodka Lemon, or Aperol Spritz are quickly and efficiently dispensed. This saves valuable time for staff and reduces waiting times for guests.

## STYLISHLY SHOWCASING SPIRITS

In bars and lounges, it is crucial to present spirits attractively to boost sales. With the **SILEXA Tap Rack ②**, you stylishly showcase your spirits, creating a visual highlight at the bar. When space is limited, the **SILEXA Bottle Flex ③** offers a compact and flexible solution for cocktail preparation. Even in small areas, high-quality drinks can be mixed quickly and easily without compromising on quality or variety.

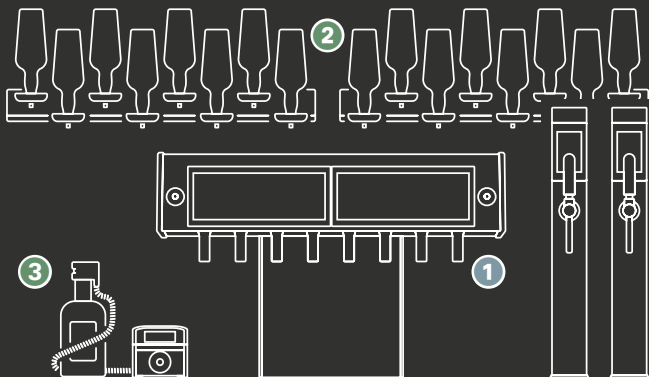

## SILEXA SPECIAL - PERFECT COCKTAILS IN RECORD TIME

The **SILEXA Dispenser Cocktail** 4 incorporates a patented hygiene solution, allowing for fast and hygienic cocktail service. Up to 24 different ingredients are precisely dosed, creating perfect cocktails in just 2 to 5 seconds. Our cocktail machine optimizes work speed and allows for the preparation of over 100 cocktails. The system is operated via a 12.3" touchscreen, where cocktails can be conveniently selected alphabetically. The ingredients come from containers such as bag-in-boxes or bottle reservoirs, which reduces both material use and labor costs.

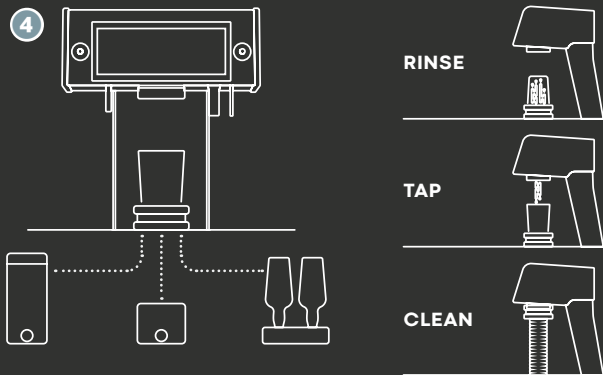





**SILEXA®**



## **HOTEL, WELLNESS & RESORT**

---

EXPLORE HOW OUR PRODUCTS CAN SIMPLIFY  
YOUR DAILY OPERATIONS AND IMPROVE  
EFFICIENCY. FIND THE IDEAL SOLUTION  
TAILORED TO YOUR NEEDS.



## EFFICIENT SOLUTIONS FOR YOUR HOTEL BAR

We offer a wide range of solutions for hotel bars that optimize daily operations and enhance guest comfort. The combination of a touchscreen **cash register** ① with the **SILEXA Dispenser** ②, **SILEXA Tower Slim** ③, **Tower Aperol Spritz** ④, and **Tower Spumante** ⑤ ensures the constant availability of essential beverages like sparkling and still water, beer, wine, mixed drinks, and spumante. Additionally, the espresso machine can be seamlessly integrated via the **SILEXA Coffee Box** ⑥. Thanks to connectivity with HMS and PMS systems, all orders can conveniently be billed to guests' rooms.

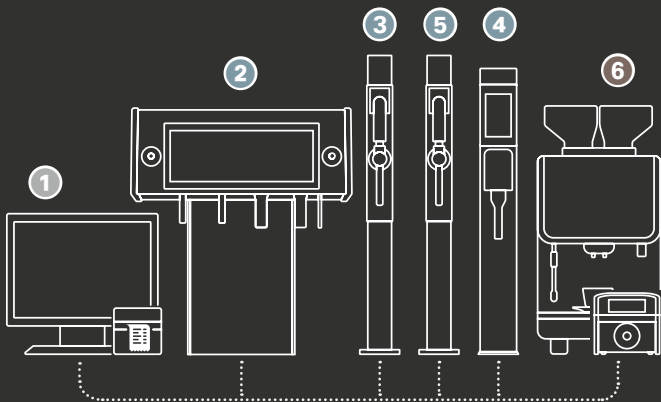

## 24/7 SELF-SERVICE SOLUTION FOR YOUR HOTEL

The **SILEXA Self-Serve Hub 7** and **PourMyBev** provide a flexible and user-friendly solution for self-service areas in hotels, resorts, and offices. Guests can easily access drinks, snacks, or coffee using their room card or hotel app. The system is directly connected to HMS and PMS software, allowing for billing to be automatically added to the room account. Various espresso machines, vending machines, or dispensing systems can be integrated, and the **Self-Serve Hub** keeps track of fill levels to ensure the best service is always provided.

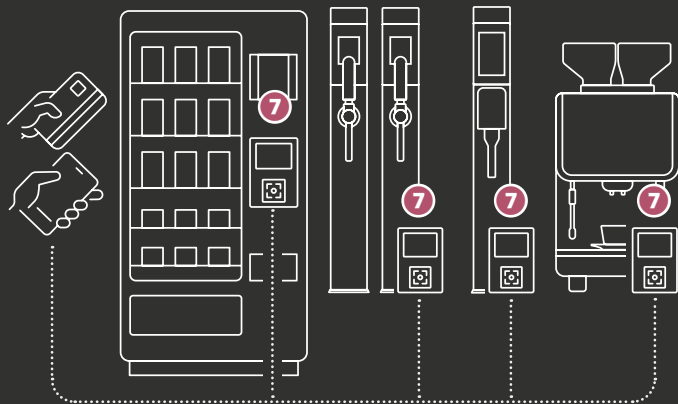

## PRACTICAL BEVERAGE SOLUTION FOR CONFERENCE ROOMS

The **SILEXA Tower Combo** allows for dispensing still and sparkling magnesium-mineralized water, along with two different flavors from a single column. It is ideal for use in conference rooms and offers maximum comfort and flexibility thanks to its compact design and a 2.8" touchscreen. Beautiful, freshly tapped carafes replace bottles, simplifying operations as the laborious task of hauling and chilling bottled mineral water is eliminated. The system contributes to an improved CO2 footprint, offers various flavors, and enables self-service during breaks, saving staff resources.





## RETAIL & SELF SERVE SHOP

---

EXPLORE HOW OUR PRODUCTS CAN SIMPLIFY YOUR DAILY OPERATIONS AND IMPROVE EFFICIENCY. FIND THE IDEAL SOLUTION TAILORED TO YOUR NEEDS.



## SILEXA SOLUTIONS IN RETAIL STORES

The **SILEXA Self-Serve Hub ①** and **SILEXA Coffee Terminal ②** offer efficient, self-service solutions for retail stores, enhancing both operations and customer experience. Our **Self-Serve Hub** allows customers to quickly access drinks, snacks, and coffee using direct payment, a loyalty card or app, streamlining purchases and reducing wait times. It integrates with existing payment systems for seamless transactions. The **Coffee Terminal** provides high-quality coffee at the push of a button, requiring no additional staff. Customers can enjoy a variety of coffee options while stores save on labor costs. These systems improve efficiency, reduce operational costs, and elevate customer satisfaction by providing a modern, convenient shopping experience.

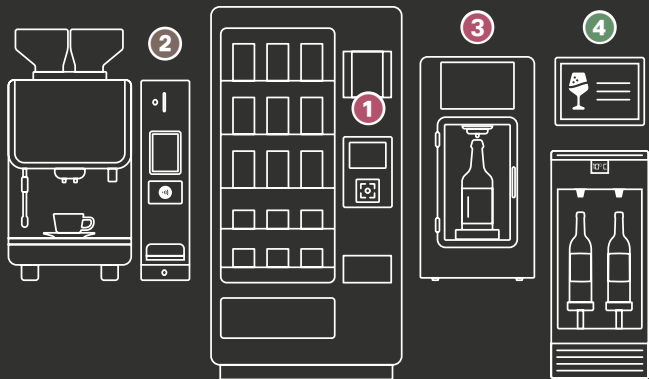

## **SILEXA SPECIAL - FRESH BEER TO GO**

The fully automated **SILEXA Growler Filler Self-Serve ③** offers customers in retail and shops the opportunity to fill fresh beer into unique bottles themselves. In just 90 seconds, up to 2 liters of beer can be perfectly portioned, foam-free, and hygienically filled. Thanks to the integrated cleaning system and simple operation via the 10.1" touchscreen, self-service is both efficient and user-friendly. Various payment options such as RFID card, QR code, credit card, or Apple Pay provide maximum flexibility for customers.

## **SILEXA SPECIAL - PERSONALIZED WINE EXPERIENCE**

With **SILEXA & By the Glass ④**, customers can select, pour, taste, and purchase wine according to their personal preferences. This self-serve solution offers an exclusive experience where payment is made directly and effortlessly at the device. With flexible payment methods and thermal cooling from 6-20°C, the wine experience is perfectly tailored to your needs. Ideal for wine boutiques or stores that want to offer their guests a unique wine-tasting experience.



*Ottakringer Fassbar beer to go solution*



## STADIUM & EVENT

---

EXPLORE HOW OUR PRODUCTS CAN SIMPLIFY YOUR DAILY OPERATIONS AND IMPROVE EFFICIENCY. FIND THE IDEAL SOLUTION TAILORED TO YOUR NEEDS.



## INNOVATIVE SOLUTIONS FOR EVENTS AND STADIUMS

**PourMyBeer for events** systems revolutionize beverage service at large events. Thanks to smart self-service solutions, large crowds can be served efficiently and quickly, while significantly reducing the need for staff. The flexible self-service technology allows visitors to pour their drinks quickly, easily, and without long wait times.

### POURMYBEER TAPWALLS - EFFICIENCY MEETS CONVENIENCE

The process starts at the **card terminal ❶**, where visitors receive an RFID card and load it with credit. They can then pour any desired amount of their favorite drink at the **PourMyBeer tap walls ❸**, as long as they have enough credit. A brief tutorial on the screen ensures even inexperienced users can pour their drink with ease. These self-service solutions not only enhance convenience but also boost revenue - beer sales can increase by up to 25% as there are no wait times, and visitors can pour their drinks at any time.

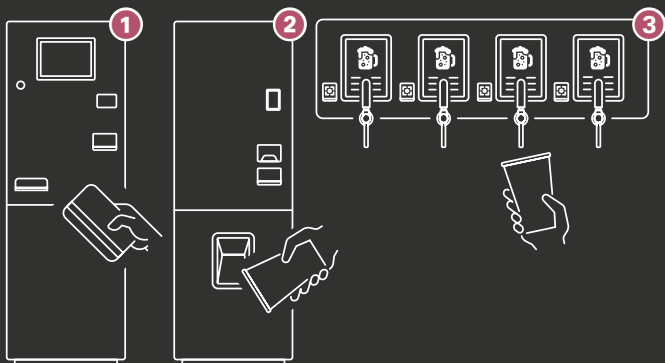

## SUSTAINABILITY THROUGH REUSABLE CONCEPTS

In addition to efficiency, **PourMyBeer for events** contributes to sustainability. At the **cup dispenser** ②, visitors receive a reusable cup, and the **cup recycler** ④ allows for the return of cups and the deposit refund onto the RFID card. By eliminating single-use plastic, these systems help promote environmental conservation.

## EXPANDABLE SOLUTIONS FOR A VARIETY OF BEVERAGES AND SNACKS

In addition to the **PourMyBeer tap walls**, the system is highly versatile and can also integrate **vending machines, coffee machines, and soft drink dispensers** ⑤. This flexibility allows venues to offer a wide range of beverages and snacks, all while maintaining the same efficient and user-friendly self-service experience. Whether it's beer, coffee, or soft drinks, the integrated system ensures seamless operations and maximizes convenience for visitors.

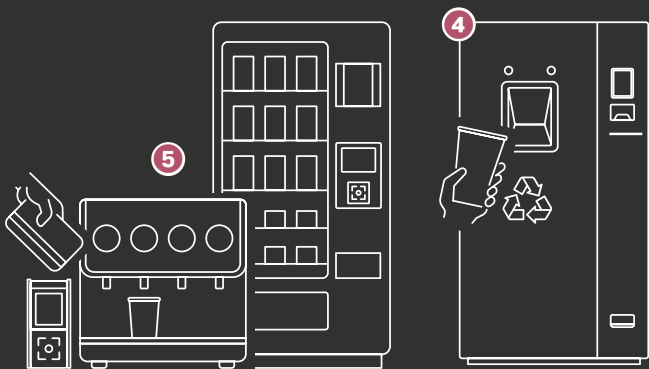

## FLEXIBLE INTEGRATION AND MAXIMUM HYGIENE

Supported by automatic cleaning of beverage lines with the **SILEXA Draft Line Cleaner** ⑥ and fully automated keg switching with the **SILEXA KEG Switcher** ⑦, the systems offer maximum efficiency and hygiene.

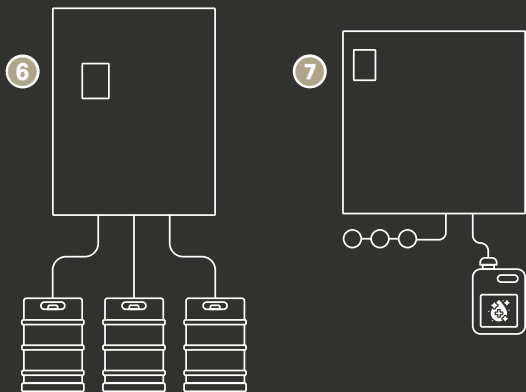

## EFFICIENT MULLED WINE DISPENSING FOR CHRISTMAS MARKETS AND APRÈS-SKI

Our **mulled wine dispenser** is the perfect solution for Christmas markets or après-ski bars. It keeps the mulled wine at the ideal temperature, never exceeding 85°C, preventing waste or overcooking. With three integrated 2.4" touchscreens, precise portion control and accurate billing are ensured, so your guests always enjoy consistent top-quality servings. Optional pumping solutions, such as membrane or bag-in-box pumps, are available, and there's also a manual version for maximum flexibility.







## **CRUISE SHIP**

---

EXPLORE HOW OUR PRODUCTS CAN SIMPLIFY YOUR DAILY OPERATIONS AND IMPROVE EFFICIENCY. FIND THE IDEAL SOLUTION TAILORED TO YOUR NEEDS.



## ENHANCING CRUISE SHIP EFFICIENCY WITH INNOVATIVE BEVERAGE SOLUTIONS

Our solutions for cruise ships are designed to enhance efficiency, improve guest experience, and ensure seamless operations. With automated systems for beverage dispensing, self-service solutions, and innovative cocktail machines, our technology simplifies operations while maintaining the highest standards of quality and hygiene. From bars to buffets, our systems integrate smoothly, reducing staff workload and providing guests with convenient, top-tier service throughout their journey. Our extensive experience on cruise ships has enabled us to continuously refine our products and tailor them even more effectively to the specific demands of the industry.

Our extensive experience on cruise ships has allowed us to continuously develop our products and tailor them even more precisely to the specific needs of the industry.



## THE ALL-IN-ONE SOLUTION FOR BREAKFAST BUFFETS

We offer space-saving breakfast buffet solutions that enable efficient use of available space while meeting the demands of fast and hygienic self-service. The **SILEXA Slim Tower Vario 1** is the ideal solution for breakfast buffets on cruise ships. This elegant all-in-one tap column allows for touchless dispensing of various beverages such as coffee, juices, milk, and water from individual taps. It replaces multiple bulky dispensers on the buffet counter, freeing up valuable space. An intelligent glass sensor and hand sensor ensure spill-free dispensing and protect guests from burns, guaranteeing maximum safety and a clean buffet operation.

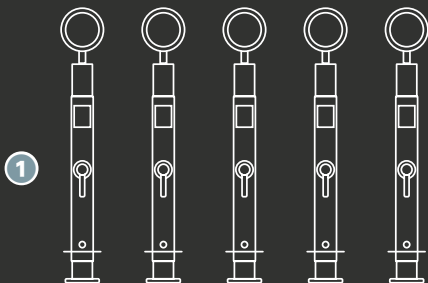

## USER-FRIENDLY SELF-SERVICE FOR BUFFETS

With **PourMyBeer** and **PourMyBev systems**, combined with the **SILEXA Dispenser ②** and **SILEXA Towers ③**, we offer flexible solutions for self-service areas on cruise ships. These systems allow guests to easily pour drinks like beer, wine, soft drinks, and coffee using their room card or resort app. For operators, these systems boost efficiency, reduce costs, and increase revenue by lowering staffing needs while allowing guests to serve themselves at any time. Guests benefit from shorter wait times, greater convenience, and the freedom to select their drinks independently and easily.

## INTEGRATED DISPENSING SYSTEMS FOR BARTENDER OPERATION WITH CASH REGISTER CONNECTIVITY

In addition to self-service solutions, cruise ships also feature dispensing systems operated by bartenders, which can be activated through **connected cash register systems**. This ensures a smooth and controlled beverage dispensing process. Furthermore, coffee machines can be seamlessly integrated into the system for both staff-operated and self-service modes, maximizing service and flexibility on board.

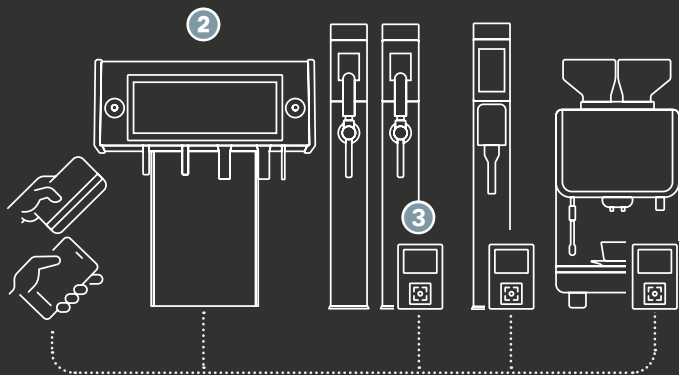

## EZ2POUR - SIMPLE BEER DISPENSING FOR GUESTS

The **SILEXA EZ2Pour Self-Serve 4** system is designed for easy and fast beer dispensing. Even inexperienced guests can intuitively operate the system. Billing is automatically processed through the room account, and with integrated age verification, it ensures that alcoholic beverages are only served to authorized individuals.

## EFFICIENT AND HYGIENIC COCKTAIL PREPARATION ON CRUISE SHIPS

The **SILEXA Dispenser Cocktail 5** offers numerous benefits for cruise ships. At the push of a button, the machine mixes perfect cocktails using up to 24 ingredients - quickly, consistently, and without the need for trained bar staff. Thanks to precise dosing and an innovative hygiene concept, waste is minimized, and every drink tastes consistently excellent. A patented cleaning program automatically ensures clean lines and meets the highest hygiene standards with USPH certification.

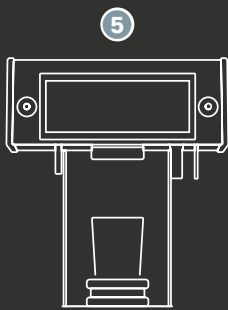
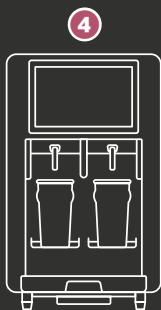

RINSE



TAP

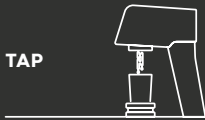

CLEAN







**SILEXA**®



# CORPORATE CATERING

---

EXPLORE HOW OUR PRODUCTS CAN SIMPLIFY  
YOUR DAILY OPERATIONS AND IMPROVE  
EFFICIENCY. FIND THE IDEAL SOLUTION  
TAILORED TO YOUR NEEDS.



## POURMYBEV - THE IDEAL SOLUTION FOR CANTEENS AND COMPANY HOSPITALITY

**PourMyBev for Canteens** offers a comprehensive and user-friendly system tailored to canteens, simplifying the payment process for employees and enhancing operational efficiency. With an intuitive **charging terminal ①**, employees can easily recharge their RFID payment cards, wristbands, or key fobs using various methods, including coins, banknotes, credit cards, or Apple Pay. This flexibility ensures smooth recharging, allowing employees to make quick, contactless payments at self-service stations.

## SEAMLESS INTEGRATION FOR ENHANCED OPERATIONS

Once recharged, the payment cards can be used for purchases at espresso machines, **vending machines ⑤**, **SILEXA Dispenser ③**, and **SILEXA Tower ④**. The system also offers seamless integration with **cash register systems ②**, enabling effortless billing and management of transactions. Additionally, integration with access control systems

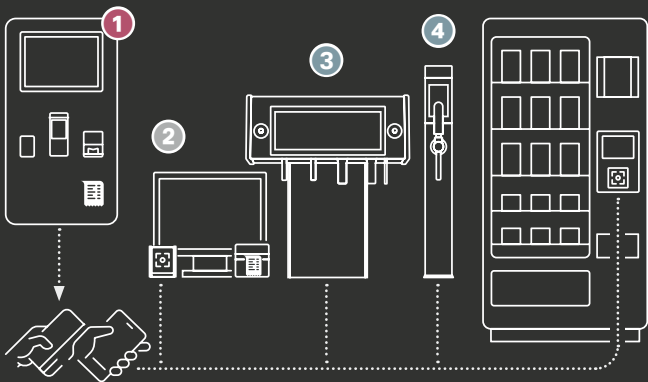

helps further optimize the flow of operations in busy canteen environments. The easy-to-manage web-based interface allows administrators to oversee the entire system efficiently, making it an ideal solution for modern, fast-paced canteen settings.

For the company, **PourMyBev** enhances operational efficiency by streamlining the payment process and reducing staff workload through self-service stations. For employees, it offers convenience with quick, contactless payments and easy recharging of RFID cards, allowing them to access a wide range of services effortlessly during their breaks. This combination improves both productivity and user satisfaction.

## **EFFICIENT BEVERAGE SOLUTION FOR KITCHENETTES AND MEETING ROOMS**

The **SILEXA Tower Combo** offers a practical beverage solution for your customers and staff. From a single compact column, both still and sparkling magnesium-mineralized water, as well as two different flavors, can be dispensed. Its space-saving design and 2.8" touchscreen make operation particularly convenient and flexible.

## **COMBINING SUSTAINABILITY AND CONVENIENCE**

Freshly tapped carafes replace the need for bottles, eliminating the hassle of carrying and chilling mineral water. At the same time, the system helps reduce the carbon footprint, provides a diverse range of beverages, and allows easy self-service during breaks.





SILEXA®



## PRIVATE HOUSEHOLD

---

EXPLORE HOW OUR PRODUCTS CAN SIMPLIFY  
YOUR DAILY OPERATIONS AND IMPROVE  
EFFICIENCY. FIND THE IDEAL SOLUTION  
TAILORED TO YOUR NEEDS.



## REDUCE PLASTIC WASTE AND AVOID HAULING BOTTLES

With the **SILEXA Slim Tower ①** for home use, you can reduce plastic waste and avoid the hassle of carrying heavy water bottles. Buying, carrying, and cooling bottles becomes unnecessary.

## FRESH WATER DIRECTLY FROM THE TAP

In combination with our **advanced filtration technology ②**, tap water can be enriched with magnesium minerals. You can dispense **chilled, sparkling, or still water ③** directly in your kitchen, giving you fresh water at the touch of a button.

## SUSTAINABLE ENJOYMENT WITHOUT DEPOSITS

Beverage dispensing systems offer a clear advantage over bottled drinks when it comes to deposit schemes. They reduce waste and eliminate the need to return empty bottles for deposit redemption, providing a more sustainable option.

On request, the system can be expanded to include flavors, beer, or wine, allowing you to customize your beverage selection.

